

**EDGE
ELECTRONICS**

**LINEAR BY DESIGN
MUSICAL BY NATURE**

Owner's Manual

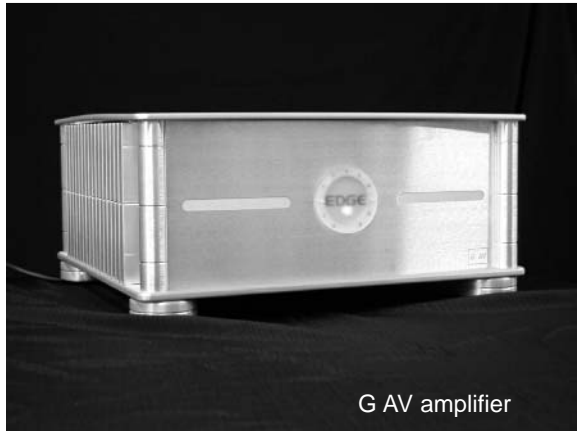

G AV amplifier

EDGE AVS and AV Amplifiers

Thank you for purchasing an EDGE Amplifier. Years of research and development has gone into the design of your amplifier to give you many years of enjoyment. The following guide will help you use and understand the features of your amplifier. Also included is technical information necessary to gain the most out of your amplifier.

Product Overview

Edge is known for award winning two channel solid state amplifiers. The G AV amplifier represents a breakthrough in size verses power output. G AV utilizes a "Powerwave" hybrid type switching power supply and output stage. "Powerwave" increases the efficiency of the amplifier while also reducing the operating temperature. Built to the same exacting standards of our two channel amplifier, but with the flexibility of multiple channels. Choose from three to seven channels of amplification and either 250 watts per channel or 500 watts per channel. The G AV is built on the same basic platform as the rest of the G series amplifiers. The new AV amplifier has the same classic lines but in a taller chassis with balanced and singled ended inputs. Start with a basic three channel amplifier and expand the G AV up to a total of seven independent channels all in a single chassis. The chassis is machined from 6061 aircraft aluminum to exacting tolerances. The G AV is visually inviting as well as technically innovative. Available in a multitude of configurations.

The G AVS/AV series use RCA type inputs (single ended inputs) or Balanced inputs. Each model is custom built with your choice of output channels and type of input.

The G AVS/AV Series is CE compliant.

Unpacking Your Amplifier

Thoroughly inspect your amplifier and packing materials for shipping damage. If you discover any damage, contact your EDGE dealer immediately. We recommend saving the packing materials for future shipment. Your amplifier has been shipped with a removable power cord and warranty card. Please fill out the warranty card and return it to EDGE.



WARNING!!!

Please remove all packaging, and let your unit sit at room temperature for at least 3 hours before plugging it in or attaching any cables. It should NOT be cold to the touch when you hook it up. Not doing this may result in damage to your unit!

Amplifier Placement

Choose a place that will support the weight of your amplifier and allow you access to the back for cable connections. Your amplifier dissipates heat through air circulation and must be kept free of any obstruction that would reduce air flow. Always place your amplifier on a hard surface and allow at least 2 inches of free space above for ventilation. Also allow adequate clearance for the AC cord and signal cables to bend behind your amplifier, we recommend leaving at least 6 inches for clearance.

AC Input Module

Located on right side of back panel.

Pictured with both RCA and Balanced connectors. The GAV is custom ordered to come with one or the other.

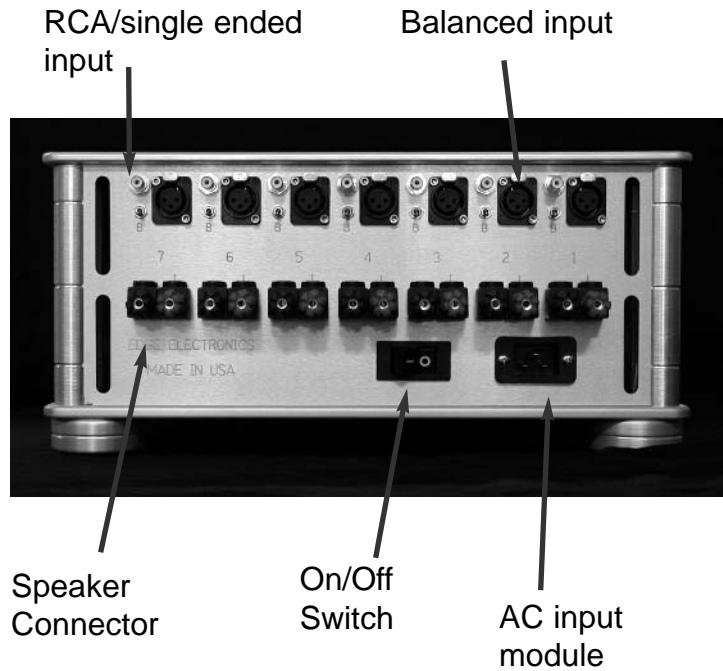

On / Off Switch

Located on rear panel in the power entry module.

On: When right side of rocker (with -) is down

Off: When left side of rocker (with 0) is down

Logo / Power Display

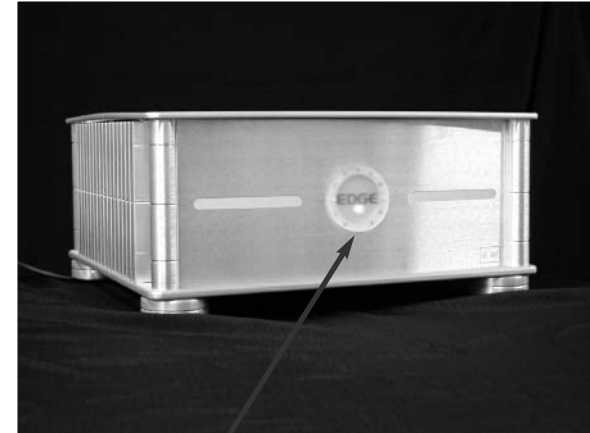

Power
L.E.D

Setup & Cable Connections

Always make sure the power switches of your preamplifier, amplifier, and source units are OFF and power indicator light is OFF before making or disconnecting ANY connections. Never plug in this unit and any components until all connections are completed.

Step 1 Speaker cables:
There are several options for terminating speaker cables. We recommend ring terminals because they minimize the possibility of a short circuit. Discuss with your dealer which cables and termination configuration will work best with your system. Attach your speaker cables to the back of your amplifier. Be careful not to over tighten the binding posts. They can be tightened by hand and usually don't require special tools.

Step 2 RCA or Balanced Interconnects:
Connect your RCA or Balanced interconnect cables from your preamplifier outputs to the corresponding left/right RCA or Balanced inputs on your amplifier.

Step 3 AC Power Cord:
Connect your AC cord to the back of the preamplifier and plug it into a grounded, surge-protected outlet.

Some EDGE amplifiers are capable of drawing high amounts of current. Depending on your loudspeakers and listening preferences, your AC outlet may not support the demands of your amplifier, limiting your systems performance. A dedicated high-current AC line may be of great benefit.

Step 4 Connect the rest of your components according to the manufactures recommendations



Warning! Never unplug the interconnect cables while your unit is on or immediately after shut off. This could cause damage to your amplifier.

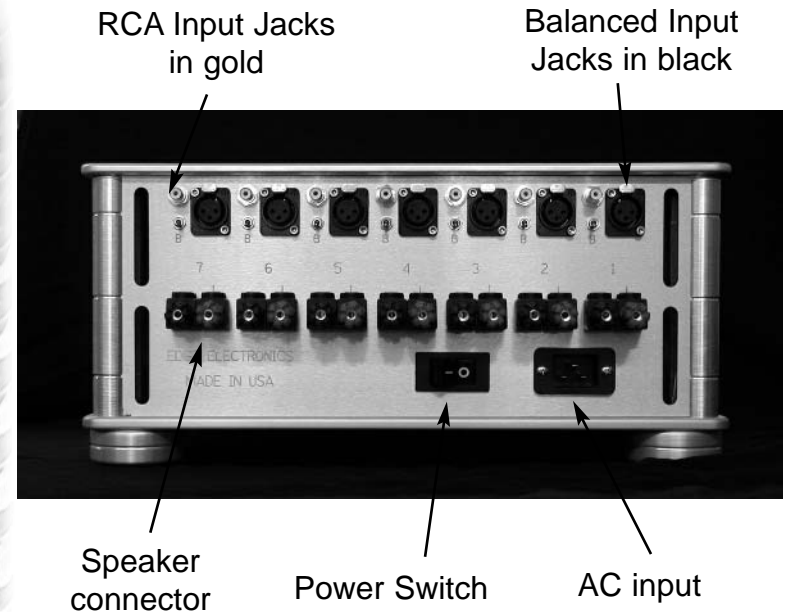

Input and speaker connector number based on number of channels ordered.

Pictured is a 7channel setup.

Pictured with both RCA and Balanced connectors. The units will be shipped with one or the other depending on the way it is ordered.



Turning Unit On & Off

Turning System On

- Step 1 Turn on the source component you are going to use (CD, DVD, DSS, etc)
- Step 2 Make sure the volume is turned all the way down
- Step 3 Turn on your preamplifier.
- Step 4 Turn on your amplifier. It will take approximately 10 seconds before the warm up relay clicks in and the amplifier is ready to play music. The logo / power display will come on as soon as the unit is turned on and approximately 10 seconds later you will hear the "click" of the relay. After "click" proceed to Step 5.
- Step 5 Select the source component on your preamplifier corresponding to the source you are going to listen to.
- Step 6 Start the source component and slowly turn the volume control up until you hear music.

Turning System Off

- Step 1 ALWAYS turn your amplifier off FIRST, and wait at least 5 minutes for power to drain*.



***WARNING:**

The internal supply capacitors in EDGE amplifiers store large amounts of energy, and can power your amplifier for several minutes, even after the power switch is turned off. Always wait at least 5 minutes before proceeding with shut down of the system. Never unplug RCA cables while unit is on or immediately after shut off

- Step 2 Turn off your preamplifier.
- Step 3 Turn off your source component.

Specifications

3 channel x 250 watt
4 channel x 250 watt
5 channel x 250 watt
6 channel x 250 watt
7 channel x 250 watt

3 channel x 500 watt
4 channel x 500 watt
5 channel x 500 watt
6 channel x 500 watt
7 channel x 500 watt

3 ch x 250 watt / 2 channel x 500 watt
3 ch x 250 watt / 3 channel x 500 watt
3 ch x 250 watt 4 channel x 500 watt
4 ch x 250 watt / 2 channel x 500 watt
5 ch x 250 watt / 2 channel x 500 watt

The G AV amplifier represents a breakthrough in size verses power output. G AV utilizes a "Powerwave" hybrid type switching power supply and output stage. "Powerwave" increases the efficiency of the amplifier while also reducing the operating temperature. Built to the same exacting standards of our two channel amplifier, but with the flexibility of multiple channels. Choose from three to seven channels of amplification and either 250 watts per channel or 500 watts per channel. The G AV is built on the same basic platform as the rest of the G series amplifiers. The new AV amplifier has the same classic lines but in a taller chassis with balanced and singled ended inputs. Start with a basic three channel amplifier and expand the G AV up to a total of seven independent channels all in a single chassis. The chassis is machined from 6061 aircraft aluminum to exacting tolerances. The G AV is visually inviting as well as technically innovative. Available in a multitude of configurations. The G AV is a perfect match for any home theater or commercial sound system where only the highest quality of sound reproduction is required. From the softest notes to the lowest bass extension nothing is lost in the translation of source signal to the speaker outputs.

15.5" D x 16.5" W x 8" H Approximate weight 60lbs.

General Rules of Operation

Never unplug the RCA cables while your unit is on or immediately after shut off.

Always wait 5 minutes before disconnecting or re-connecting cables.

Never operate your amplifier in a damp or wet location.

Never expose the unit to fluids. If the unit gets wet, IMMEDIATELY unplug the unit FROM THE WALL, and call your EDGE dealer.

Never operate your amplifier during an electrical storm.

If your amplifier has been exposed to cold temperatures, allow it to warm up before turning it on.

Never apply liquid cleaners directly to your amplifier. (See care and maintenance section)

Never attempt to open or service your amplifier. If a problem occurs, contact your EDGE dealer immediately.

Never replace fuse with a type or value different than those specified.

Never bypass any fuses.

Always turn the volume down on your preamplifier before selecting a new source.

Always disconnect your entire system from the AC power before connecting or disconnecting any cables, components or when cleaning.

Always keep electrical components away from children and pets.

If you have any questions about your amplifier that is not addressed here, please contact your EDGE dealer.

Care & Maintenance

To remove dust from your amplifier, use a feather-duster or lint-free soft cloth. To remove dirt and fingerprints, use a standard non abrasive liquid household cleaner and a soft cloth. Slightly dampen the cloth first and then lightly clean the surface. Never spray or apply the cleaner directly to the amplifier. Be sure the cloth is DAMP and not saturated to prevent dripping the cleaner into the amplifier.

Limited Warranty

EDGE components are warranted to be free from defect in material and workmanship under normal use, for a period of two (2) years, to the original consumer purchaser, from the date of purchase. During the warranty period, and upon proof of purchase, any EDGE component exhibiting defects in materials and/or workmanship, will be repaired or replaced, at our option, without charge for either parts or labor, at our factory. The warranty will not apply to an EDGE component that has been abused or altered.

Any EDGE component not performing properly may be returned (freight prepaid) to the factory for evaluation. The factory will pay for shipping charges to return the unit only in the event that the component is found to be defective as above mentioned. Other stipulations may apply to shipping charges.

Neither this warranty, nor any other warranty including any implied warranties, shall extend beyond the warranty period. No responsibility is assumed for any incidental or consequential damages.



Toll-free : 877.461.7443

Phone : 239.945.6227

Fax : 239.945.6338

EDGE Electronics

P.O. Box 101123

Cape Coral, FL 33910-1123

www.edgeamp.com

e-mail at: edgeamps@aol.com

